



OWNER'S MANUAL

ST1100 A-T

HONDA

IMPORTANT NOTICE

- **OPERATOR AND PASSENGER**

This motorcycle is designed to carry the operator and one passenger. Never exceed the maximum weight capacity as shown on the tyre information label.

- **ON-ROAD USE**

This motorcycle is designed to be used only on the road.

- **READ THIS OWNER'S MANUAL CAREFULLY**

Pay special attention to statements preceded by the following words:

▲ WARNING

Indicates a strong possibility of severe personal injury or death if instructions are not followed.

CAUTION:

Indicates a possibility of personal injury or equipment damage if instructions are not followed.

NOTE: Gives helpful information.

This manual should be considered a permanent part of the motorcycle and should remain with the motorcycle when resold.

**HONDA PAN EUROPEAN
ST1100
OWNER'S MANUAL**

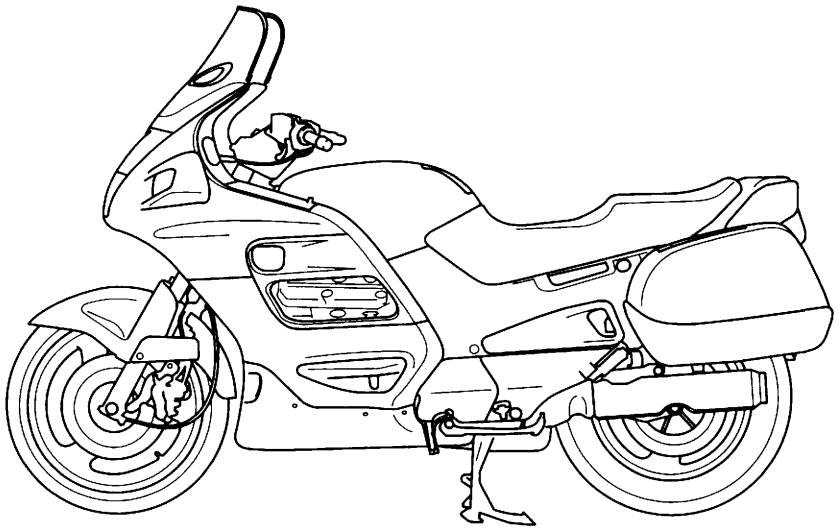

All information in this publication is based on the latest production information available at the time of approval for printing. HONDA MOTOR CO., LTD. reserves the right to make changes at any time without notice and without incurring any obligation. No part of this publication may be reproduced without written permission.

WELCOME

The motorcycle presents you a challenge to master the machine, a challenge to adventure. You ride through the wind, linked to the road by a vehicle that responds to your commands as no other does. Unlike an automobile, there is no metal cage around you. Like an airplane, a pre-ride inspection and regular maintenance are essential to your safety. Your reward is freedom.

To meet the challenges safely, and to enjoy the adventure fully, you should become thoroughly familiar with this owner's manual **BEFORE YOU RIDE THE MOTORCYCLE.**

When service is required, remember that your Honda dealer knows your motorcycle best. If you have the required mechanical "know-how" and tools, your dealer can supply you with an official Honda Shop Manual to help you perform many maintenance and repair tasks.

Pleasant riding, and thank you for choosing a Honda!

- Following codes in this manual indicate each country.

Sales Name: Pan European

| | | | |
|----|---|----|-------------|
| AR | Austria | IT | Italy |
| E | UK | N | Norway |
| ED | European direct sales Belguim Holland Portugal | SP | Spain |
| | | SW | Switzerland |
| F | France | | |
| FI | Finland | | |
| G | Germany | | |

Sales Name: ST1100

| | |
|---|-----------|
| U | Australia |
|---|-----------|

- The specifications may vary with each local.
- Following words in this manual indicate each mechanism.
 - CBS: Combined Brake System
 - ABS: Anti-lock Brake System
 - TCS: Traction Control System

CONTENTS

OPERATION

| Page | | Page | |
|------|--|------|-------------------------------|
| 1 | MOTORCYCLE SAFETY | 38 | Helmet Holders |
| 1 | Safe Riding Rules | 38 | Luggage Tie-Down Hooks |
| 2 | Protective Apparel | 39 | Document Compartment |
| 3 | Modifications | 40 | Digital Clock |
| 4 | Loading and Accessories | 41 | Saddlebags |
| | | 43 | Fairing Pockets |
| | | 44 | Rear view mirrors |
| 7 | PARTS LOCATION | 45 | Headlight Beam Adjustment |
| 10 | Instruments and Indicators | 46 | Accessory (ACC) Terminal |
| 16 | MAJOR COMPONENTS (Information you need to operate this motorcycle) | 47 | OPERATION |
| 16 | Rear Suspension | 47 | Pre-ride Inspection |
| 18 | Brakes | 48 | Starting the Engine |
| 21 | Clutch | 49 | Running-in |
| 22 | Coolant | 52 | Riding |
| 24 | Fuel | 53 | Braking |
| 27 | Engine Oil | 58 | Traction Control System (TCS) |
| 29 | Final Drive Oil | 62 | Parking |
| 30 | Tubeless Tyres | 63 | Anti-theft Tips |
| 34 | ESSENTIAL INDIVIDUAL COMPONENTS | | |
| 34 | Ignition Switch | | |
| 35 | Right Handlebar Controls | | |
| 36 | Left Handlebar Controls | | |
| 37 | FEATURES (Not required for operation) | | |
| 37 | Steering Lock | | |
| 37 | Seat | | |

CONTENTS

MAINTENANCE

| Page | | Page | |
|------|------------------------------|------|------------------------------------|
| 64 | MAINTENANCE | 84 | FRAME/WHEELS/ BRAKES |
| 65 | Maintenance Schedule | 84 | Front Wheel Removal |
| 67 | Tool Kit | 90 | Rear Wheel Removal |
| 68 | Serial Numbers | 93 | Brake Pad Wear |
| 68 | Colour Label | 94 | Brake System Inspection |
| 69 | Maintenance Precau- tions | 95 | Side Stand |
| 70 | Cover Removal | | |
| | | 96 | ELECTRICAL |
| 75 | FILTERS/LUBRICATION | 96 | Battery |
| 75 | Engine Oil And Filter | 98 | Fuse Replacement |
| 78 | Air Cleaner | | |
| | | 103 | CLEANING |
| 80 | ENGINE | | |
| 80 | Spark Plugs | 105 | STORAGE GUIDE |
| 82 | Idle Speed | 105 | Storage |
| | | 106 | Removal From Storage |
| 83 | DRIVE TRAIN | | |
| 83 | Final Drive Oil | 107 | SPECIFICATIONS |
| | | | |
| | | 110 | NOISE EMISSION (AUSTRALIA ONLY) |

MOTORCYCLE SAFETY

SAFE RIDING RULES

▲ WARNING

- ***Motorcycle riding requires special efforts on your part to ensure your safety. Know these requirements before you ride:***
 1. Always make a pre-ride inspection (page 46) before you ride the motorcycle.
You may prevent an accident or equipment damage.
 2. Many accidents involve inexperienced riders. Most states require a special motorcycle riding test or license. Make sure you are qualified before you ride. NEVER lend your motorcycle to an inexperienced rider.
 3. Many automobile/motorcycle accidents happen because the automobile driver does not “see” the motorcyclist.
Make yourself conspicuous to help avoid the accident that wasn’t your fault:
 - Wear bright or reflective clothing.
 - Don’t ride in another motorist’s “blind spot.”
 4. Obey all national and local laws and regulations.
 - Excessive speed is a factor in many accidents. Obey the speed limits, and NEVER travel faster than conditions warrant.
 - Signal before you make a turn or lane change. Your size and maneuverability can surprise other motorists.
 5. Don’t let other motorists surprise you. Use extra caution at intersections, parking lot entrances and exits, and driveways.
 6. Keep both hands on the handlebars and both feet on the footpegs while riding. A passenger should hold on to the motorcycle or the operator with both hands and keep both feet on the passenger footpegs.

CAUTION:

- ***Do not ride over curbs or rub the wheel against an obstacle, as wheel damage may result.***

MOTORCYCLE SAFETY

PROTECTIVE APPAREL

1. Most motorcycle accident fatalities are due to head injuries: ALWAYS wear a helmet. You should also wear a face shield or goggles as well as boots, gloves, and protective clothing. A passenger needs the same protection.
2. The exhaust system becomes hot during operation, and it remains hot for a while after stopping the engine. Be careful not to touch the exhaust system while it is hot. Wear clothing that fully covers your legs.
3. Do not wear loose clothing which could catch on the control levers, footpegs, or wheels.

MODIFICATIONS

⚠ WARNING

- *Modification of the motorcycle, or removal of original equipment, may render the vehicle unsafe or illegal. Obey all federal, state and local equipment regulations.*

MOTORCYCLE SAFETY

LOADING AND ACCESSORIES

▲ WARNING

- *To prevent an accident, use extreme care when adding and riding with accessories and cargo. Addition of accessories and cargo can reduce a motorcycle's stability, performance and safe operating speed. Never ride an accessory-equipped motorcycle at speeds above 130 km (80 mph). And remember that this 130 km (80 mph) limit may be reduced by installation of non-Honda accessories, improper loading, worn tires and overall motorcycle condition, poor road or weather conditions. These general guidelines may help you decide whether or how to equip your motorcycle, and how to load it safely.*

Loading

The combined weight of the rider, passenger, cargo and additional accessories must not exceed the maximum weight capacity;

201 kg (443 lbs) ...without CBS/ABS/TCS (Except AR, SW)

200 kg (441 lbs) ...without CBS/ABS/TCS (AR, SW)

191 kg (421 lbs) ...with CBS/ABS/TCS (Except AR, SW)

190 kg (419 lbs) ...with CBS/ABS/TCS (AR, SW)

Cargo weight alone should not exceed 27 kg (60 lbs).

1. Keep cargo and accessory weight low and close to the center of the motorcycle. Load weight equally on both sides to minimize imbalance. As weight is located farther from the motorcycle's center of gravity, handling is proportionally affected.
2. Adjust tire pressure (page 31).
3. All cargo and accessories must be secure for stable handling. Recheck cargo security and accessory mounts frequently.

-
4. Do not attach large, heavy items to the handlebars, fork, or fender. Unstable handling or slow steering response may result.
 5. Do not exceed the maximum weight capacity of Honda accessories.
 - Saddlebag: **9 kg (20 lbs) Each side**
 - Fairing pocket: **2 kg (4.5 lbs) Each side**
 6. The Honda fairing and saddlebag are designed for this motorcycle only. Do not install them on any other motorcycle.
 7. Do not store articles between fairing and motorcycle. They may interfere with steering causing loss of control.
 8. Do not use the handlebars to hold the motorcycle with a rope during transportation or the handlebars may be bent.

Accessories

Genuine Honda accessories have been specifically designed for and tested on this motorcycle. Because the factory cannot test all other accessories, you are personally responsible for proper selection, installation, and use of non-Honda accessories.

Always follow the guidelines under Loading, and these:

1. Carefully inspect the accessory to make sure it does not obscure any lights, reduce ground clearance and banking angle, or limit suspension travel, steering travel or control operation.
2. Large fork-mounted fairings or windshields, or poorly designed or improperly mounted fairings can produce aerodynamic forces that cause unstable handling. Do not install fairings that decrease cooling air flow to the engine.

MOTORCYCLE SAFETY

3. Accessories which alter your riding position by moving hands or feet away from controls may increase reaction time in an emergency.
4. Do not add electrical equipment that will exceed the motorcycle's electrical system capacity. A blown fuse could cause a dangerous loss of lights or engine power.
5. This motorcycle was not designed to pull a sidecar or trailer. Handling may be seriously impaired if so equipped.
6. Any modification of the cooling system may cause overheating and serious engine damage. Do not modify the radiator shrouds or install accessories which block or deflect air away from the radiator.

PARTS LOCATION

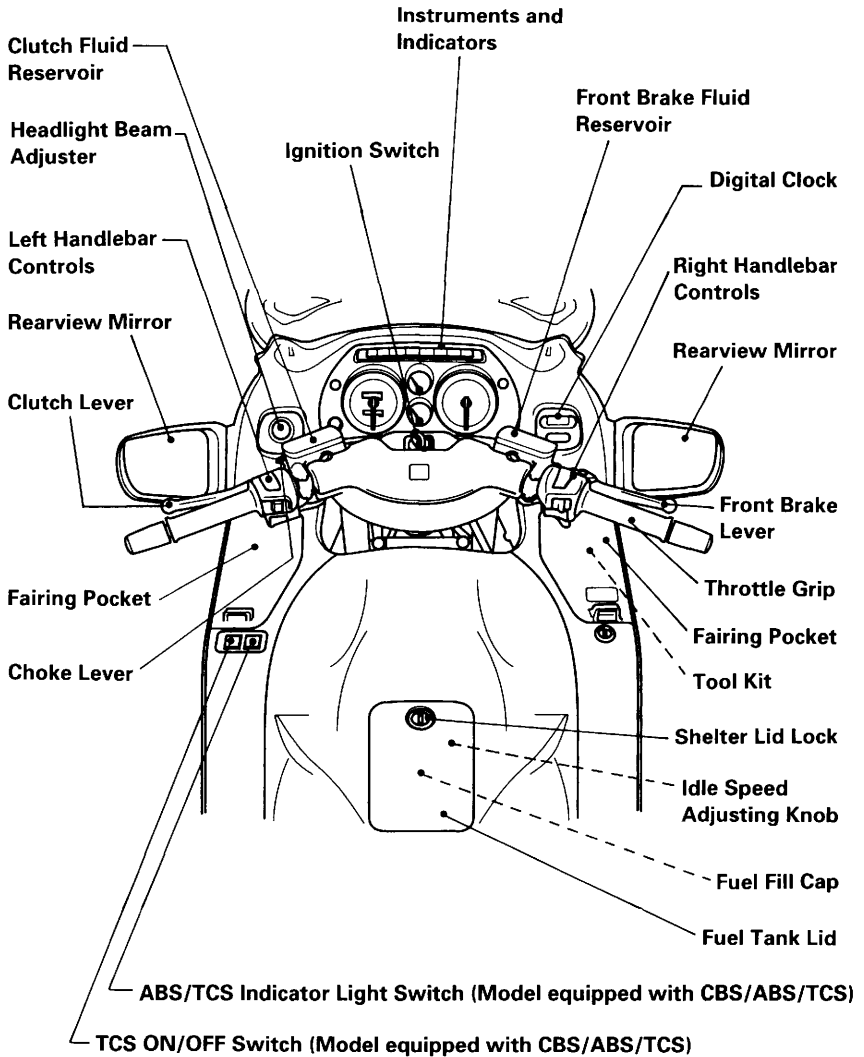

PARTS LOCATION

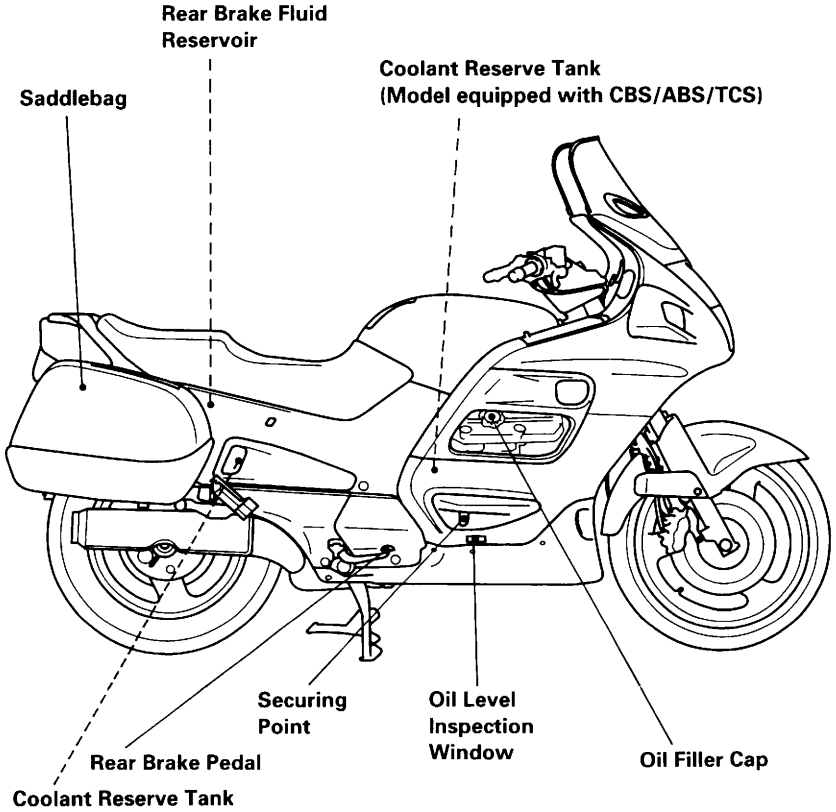

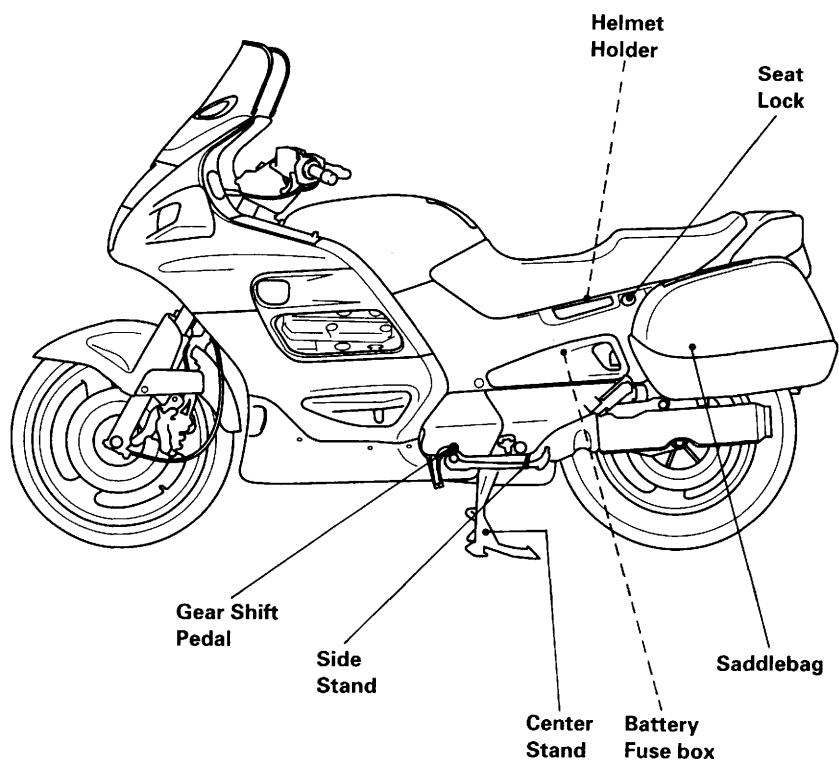

PARTS LOCATION

INSTRUMENTS AND INDICATORS

The indicators are incorporated in the instrument panel. Their functions are described on the following pages.

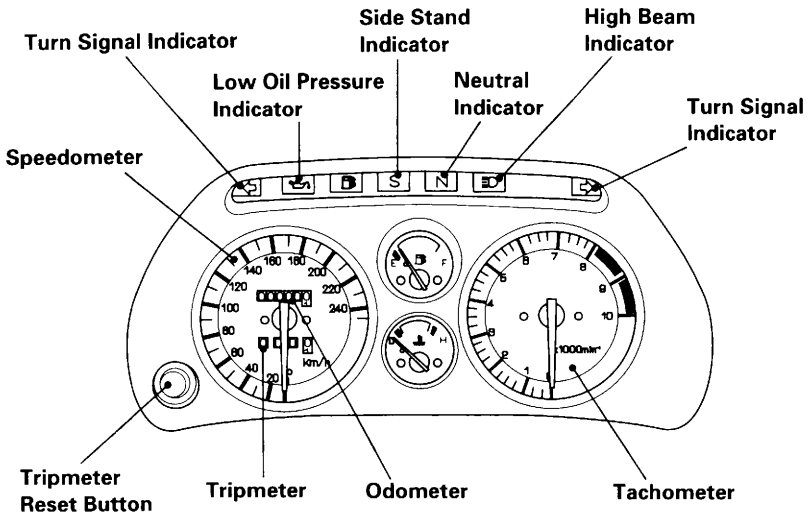

(For model equipped with CBS/ABS/TCS)

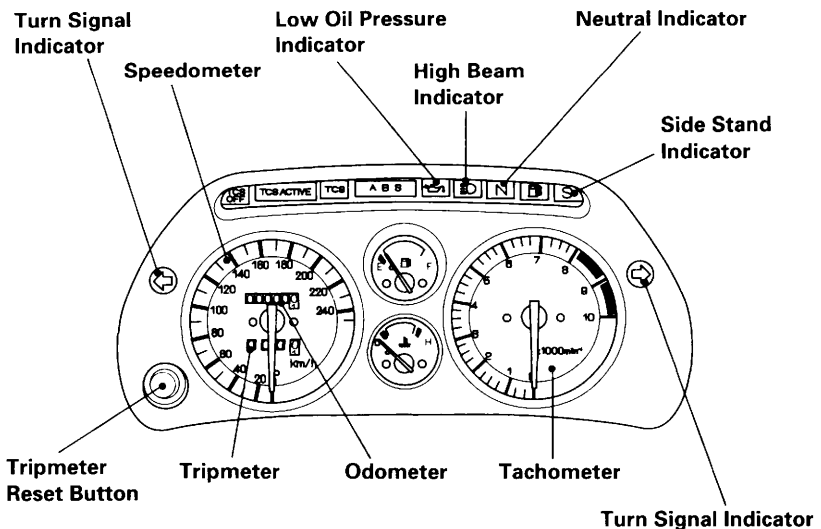

Speedometer: shows riding speed.

Tachometer: shows engine rpm.

Never allow the tachometer needle to enter the red zone, even after the engine has been broken in.

CAUTION:

- *The red zone indicates the maximum limits of engine speed and running the engine in the red zone may adversely affect its service life.*

Turn Signal Indicators (green): Flashes when the turn signal operates.

Odometer: Shows accumulated mileage.

Tripmeter: Shows mileage per trip.

Tripmeter Reset Button: Pushing the button resets the tripmeter to zero (0)

High Beam Indicator (blue): Lights when the headlight is on high beam.

Neutral Indicator (green): Lights when the transmission is in neutral.

Low Oil Pressure Indicator (red):

Lights when engine oil pressure is below the normal operating range. Should also light when the ignition switch is ON and the engine is not running. Should go off when the engine starts, except for occasional flickering at or near idling speed when the engine is warm.

CAUTION:

- *Running the engine with insufficient oil pressure may cause serious engine damage.*

Side Stand Indicator (amber):

Lights when the side stand is put down.

Before parking, check that the side stand is fully down; the light only indicates the side stand ignition cut-off system (page 47) is activated.

PARTS LOCATION

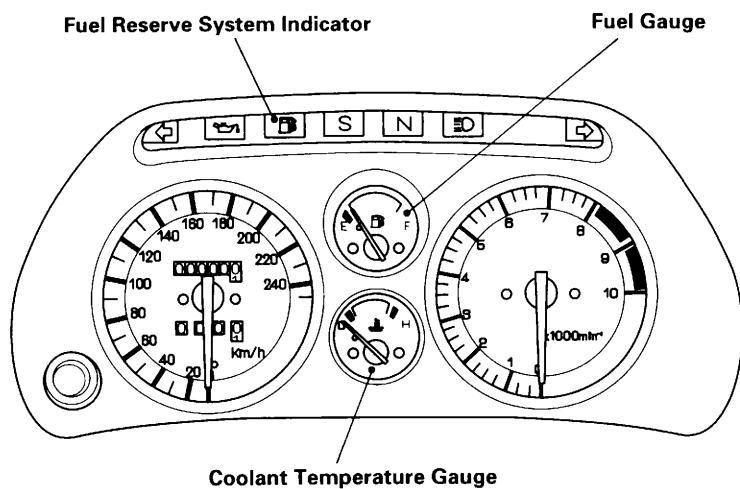

(For model equipped with CBS/ABS/TCS)

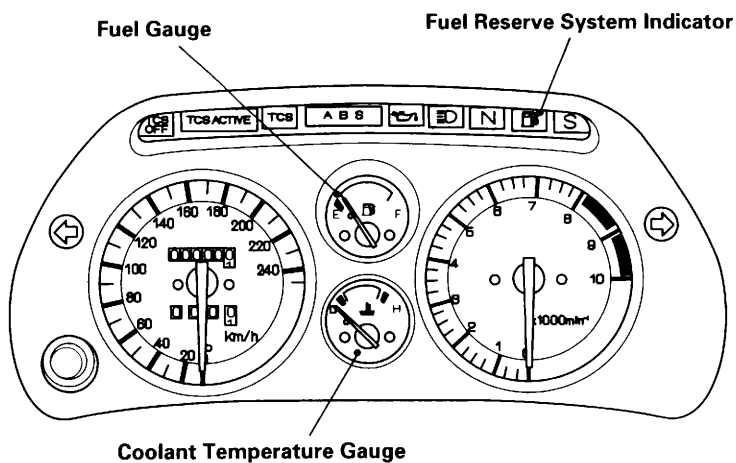

Fuel Reserve System Indicator:

When this Indicator comes on while riding, there are about 5 liters (1.3 US gal, 1.1 Imp gal) left in the tank. Should also light for a few seconds and go off when the ignition switch is turned ON.

Fuel Gauge:

The fuel gauge shows the approximate fuel supply available. At F (Full) there are 28 liters (7.4 US gal, 6.1 Imp gal), including the reserve supply.

When the gauge needle enters the red band, the fuel level is low and you should refill the tank as soon as possible. The amount of fuel left in the tank when the needle enters the red band is approximately 3.5 liters (0.9 US gal, 0.8 Imp gal)

Coolant Temperature Gauge:

The normal operating temperature range is the zone between the C (cold) and H (hot) marks. Wait for the temperature gauge needle to move above the C mark before riding. If the needle reaches the H mark, stop the engine and check the reserve tank coolant level (page 22).

Do not ride the motorcycle until the problem has been corrected.

CAUTION:

- ***Exceeding maximum running temperature may cause serious engine damage.***

PARTS LOCATION

(For model equipped with CBS/ABS/TCS)

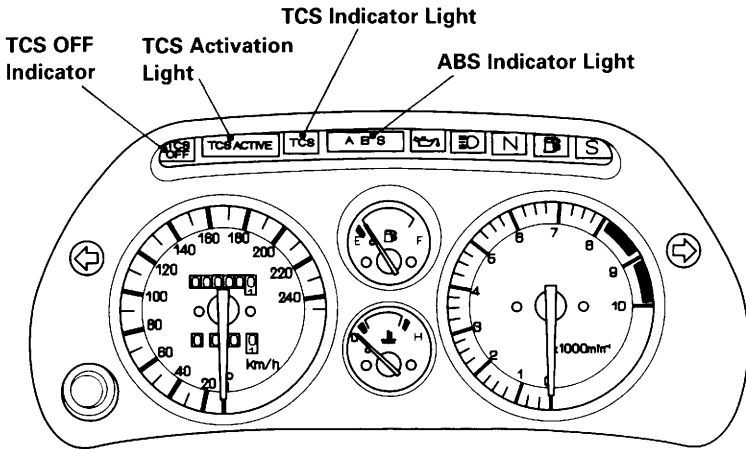

Anti-lock Brake System (ABS) Indicator Light:

This light normally comes on when the ignition is turned ON and goes off after starting to ride.

If there is a problem with the Anti-lock Brake System, this light comes on and remains on — or blinks. (See chart on page 15.) For information about ABS, see page 54.

Traction Control System (TCS) Indicator Light:

This light normally comes on when the ignition is turned ON and goes off after starting to ride.

If there is a problem with the Traction Control System, this light comes on and remains on — or blinks. (See chart on page 15.) For more information about TCS, see page 58.





TCS Activation Light:

This light lights when the traction control system is activated to regulate the engine (see page 58). It will normally light for a few seconds when you turn the ignition switch ON.

TCS OFF Indicator:

This indicator lights when the traction control system is OFF (see pages 59 and 60). It will normally light for a few seconds when you turn the ignition switch ON.

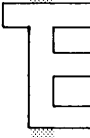
ABS and TCS Indicator Light Operation

| | Ignition "ON" | After Starting to Ride | Normal: OK Not working: NG |
|---------------------|--|---|-------------------------------|
| ABS Indicator Light |  <input type="checkbox"/> Comes ON  Blinks |   <ul style="list-style-type: none"> Goes OFF Remains ON Blinks | OK NG NG NG |
| TCS Indicator Light | <input type="checkbox"/> Comes ON  Blinks |  <ul style="list-style-type: none"> Goes OFF Remains ON Blinks | OK NG NG NG |

If either the ABS or TCS Indicator Light does not operate properly, See your authorized Honda dealer for service.

MAJOR COMPONENTS

(Information you need to operate this motorcycle)

⚠ WARNING

- *If the Pre-ride Inspection (page 47) is not performed, severe personal injury or vehicle damage may result.*

REAR SUSPENSION

Spring preload adjustment:

The rear shock absorber has five adjustment positions for different load or riding conditions.

Remove the right saddlebag (page 42) and right side cover (page 71).

Use the pin spanner in the tool kit to adjust the rear shock.

Position 1 is for a light load and smooth road conditions.

Position 2 is the standard position.

Positions 3 to 5 increase spring preload for a stiffer rear suspension, and can be used when the motorcycle is more heavily loaded.

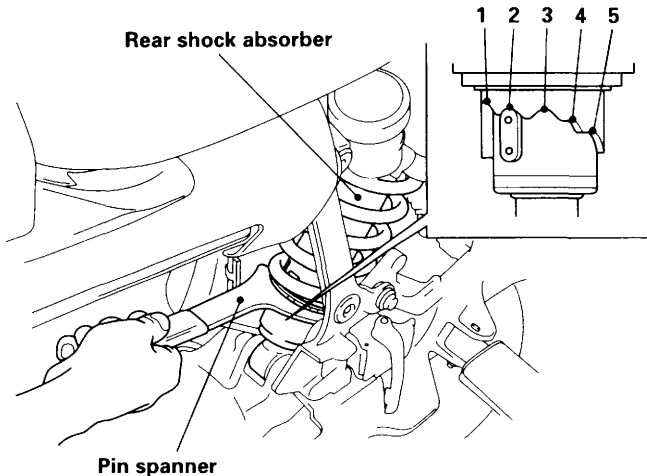

Rebound Damping adjustment:

The rebound damping adjuster has four adjustment positions.

To adjust to the standard position, proceed as follows:

1. Turn the adjuster clockwise until it stops.
2. Turn the adjuster counterclockwise 1 turn (model equipped with CBS/ABS/TCS: 1/2 turn) to align the punch mark on the adjuster with the reference mark.

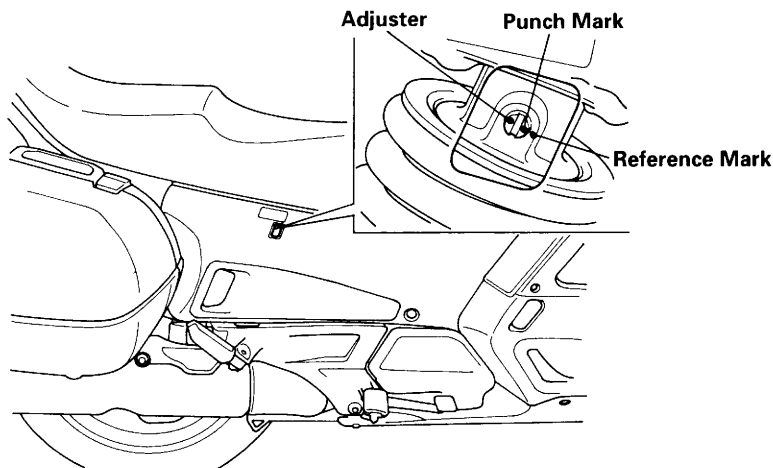

Recommended adjuster positions:

| CONDITIONS | | REBOUND DAMPING Turn clockwise from standard position | SPRING PRELOAD |
|------------|-------|--|----------------|
| Rider | Cargo | | |
| One | — | 0° (no adjustment) | 1 or 2 |
| One | Cargo | 180° (1/2 turn) | 3 |
| Two | — | 270° (3/4 turn) | 4 |
| Two | Cargo | 270° or 360° (3/4 to 1 full turn) | 5 |

(For model equipped with CBS/ABS/TCS)

| CONDITIONS | | REBOUND DAMPING Turn clockwise from standard position | SPRING PRELOAD |
|------------|-------|--|----------------|
| Rider | Cargo | | |
| One | — | 0° (no adjustment) | 1 or 2 |
| One | Cargo | 0° (no adjustment) | 3 |
| Two | — | 90° (1/4 turn) | 4 |
| Two | Cargo | 90° or 180° (1/4 to 1/2 full turn) | 5 |

MAJOR COMPONENTS

(Information you need to operate this motorcycle)

BRAKES

Both front and rear brakes are hydraulic disc types.

As the brake pads wear, the brake fluid level will drop. Therefore, the brake fluid level and pad wear must be inspected periodically. The system must be inspected frequently to ensure there are no fluid leaks. If the control lever or pedal free travel becomes excessive and the brake pads are not worn beyond the recommended limit (page 93), there is probably air in the brake system and it must be bled. See your authorized Honda dealer for this service.

Brake Fluid Level:

▲ WARNING

- ***Brake fluid may cause irritation. Avoid contact with skin or eyes. In case of contact, flush thoroughly with water and call a doctor if your eyes were exposed.***
- ***KEEP OUT OF REACH OF CHILDREN.***

CAUTION:

- ***When adding brake fluid, be sure the reservoir is horizontal before the cap is removed or brake fluid may spill out.***
- ***Use only DOT 4 brake fluid from a sealed container.***
- ***Never allow contaminants such as dirt or water to enter the brake fluid reservoir.***
- ***Handle brake fluid with care because it can damage plastic and painted surfaces.***

Check that the fluid level is above the LOWER level mark with the motorcycle in an upright position.

Brake fluid must be added to the reservoir whenever the fluid level begins to reach the LOWER level mark.

Front Brake

The front brake motor cylinder is located on the right handlebar. Fill the reservoir with DOT 4 BRAKE FLUID from a sealed container up to the upper level mark.

Reinstall the removed parts in the reverse order of removal. Tighten the screws securely.

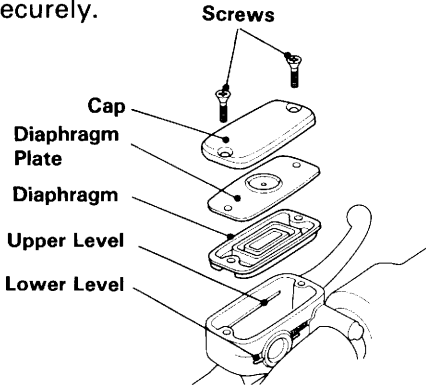

Rear Brake

1. Remove the right saddlebag (page 42) and right side cover (page 71).
2. Remove the cap.
3. Fill the reservoir with DOT 4 BRAKE FLUID from a sealed container up to the upper level mark.
4. Reinstall the removed the cap.

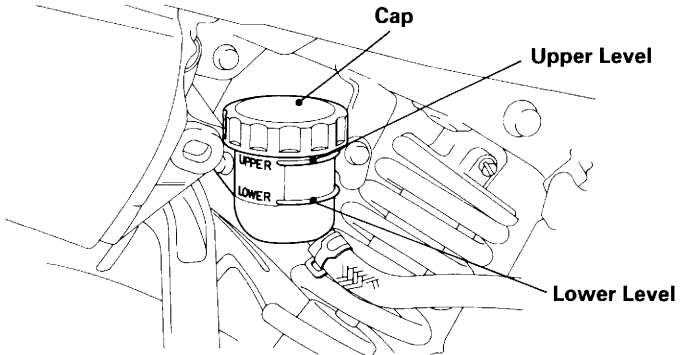

Other Checks:

Make sure there are no fluid leaks. Check for deterioration or cracks in the hoses and fittings.

MAJOR COMPONENTS

(Information you need to operate this motorcycle)

Front Brake Lever:

The distance between the tip of the brake lever and the grip can be adjusted by turning the adjuster.

CAUTION:

- ***Align the arrow on the brake lever with the index mark on the adjuster.***

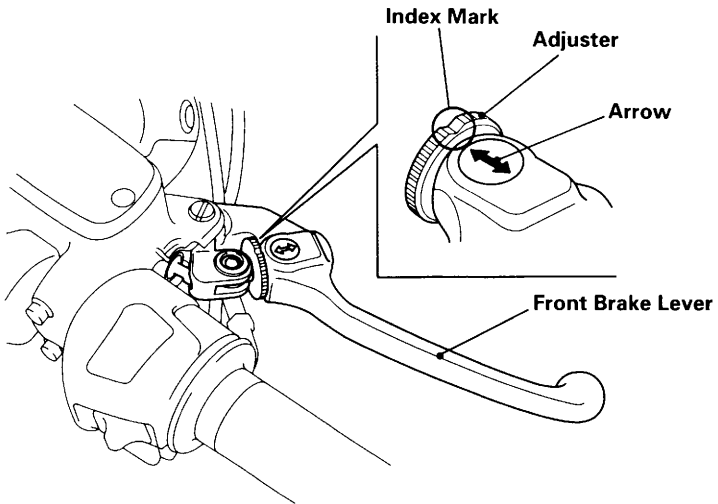

CLUTCH

This motorcycle has a hydraulically actuated clutch. There are no adjustments to perform but the clutch system must be inspected periodically for fluid level and leakage. If the control lever freeplay becomes excessive and the motorcycle creeps or stalls when shifted into gear, or if the clutch slips, causing acceleration to lag behind engine speed, there is probably air in the clutch system and it must be bled out. See your authorized Honda dealer for this service.

Fluid level:

Check that the fluid level is above the LOWER level mark. If the fluid level is near the LOWER level mark, it indicates fluid leakage. See your authorized Honda dealer for repair.

Other Checks:

Make sure there are no fluid leaks. Check for deterioration or cracks in the hose and fittings.

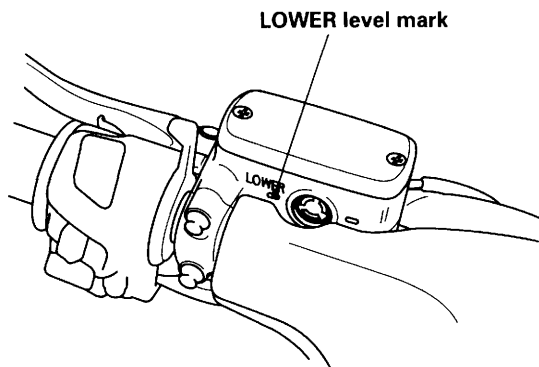

MAJOR COMPONENTS

(Information you need to operate this motorcycle)

COOLANT

Coolant Recommendation

The owner must properly maintain the coolant to prevent freezing, overheating, and corrosion. Use only high quality ethylene glycol antifreeze containing corrosion protection inhibitors specifically recommended for use in aluminum engines. (SEE ANTIFREEZE CONTAINER LABEL).

CAUTION:

- ***Use only low-mineral drinking water or distilled water as a part of the antifreeze solution. Water that is high in mineral content or salt may be harmful to the aluminum engine.***

The factory provides a 50/50 solution of antifreeze and water in this motorcycle. This coolant solution is recommended for most operating temperatures and provides good corrosion protection. A higher concentration of antifreeze decreases cooling system performance and is recommended only when additional protection against freezing is needed. A concentration of less than 40/60 (40% antifreeze) will not provide proper corrosion protection. During freezing temperatures, check the cooling system frequently and add higher concentrations of antifreeze (up to a maximum of 60% antifreeze) if required.

Inspection

The coolant reserve tank is behind the right side cover (right side cowl for model equipped with CBS/ABS/TCS). Check the coolant level in the reserve tank while the engine is at normal operating temperature. If the coolant is low, remove the right side cover (page 71) or air duct/maintenance cover (page 71) and add coolant to the reserve tank as required to bring the coolant level to the UPPER level mark.

If the reserve tank is empty, or if coolant loss is excessive, check for leaks and see your authorized Honda dealer for repair.

WARNING

- ***Do not remove the radiator cap when the engine is hot. The coolant is under pressure and could scald you.***
- ***Keep hands and clothing away from the cooling fan, as it starts automatically.***

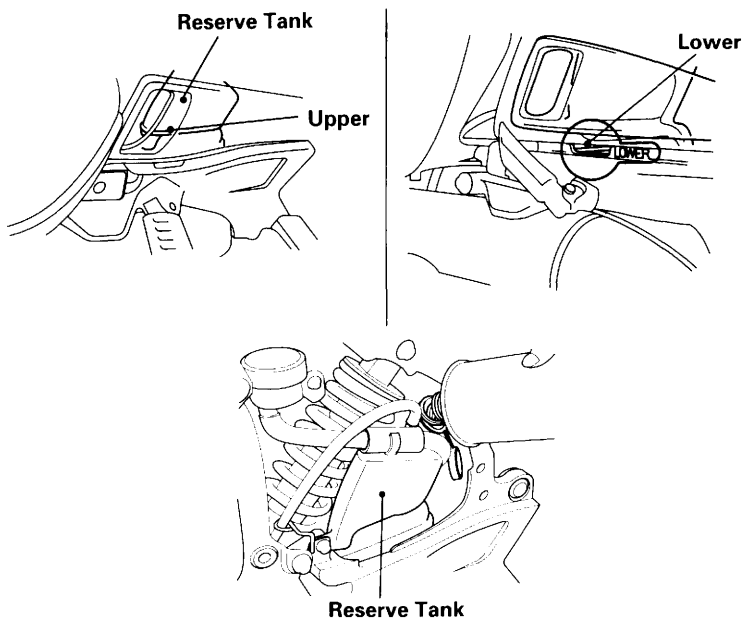

(Model equipped with CBS/ABS/TCS)

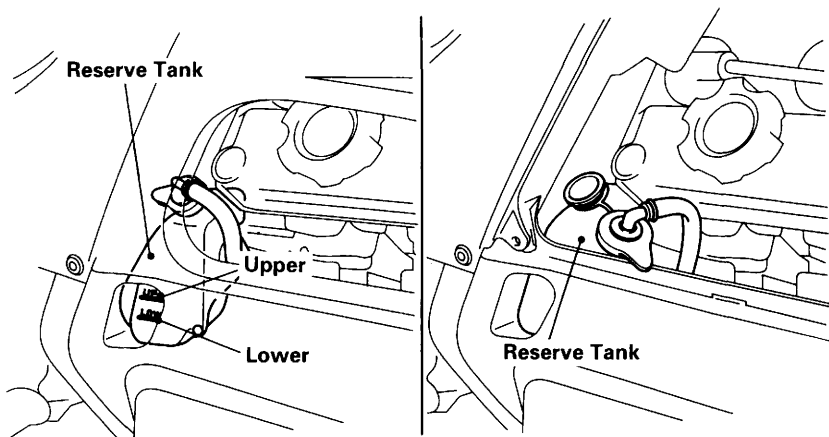

MAJOR COMPONENTS

(Information you need to operate this motorcycle)

FUEL

Automatic Fuel ON-OFF

Fuel will flow to the carburetors only when the engine is started or is running.

Fuel Tank

Fuel tank capacity is 28 ℓ (7.4 US gal, 6.1 Imp gal). Insert the ignition key and turn it clockwise to open the fuel filler compartment. Turn the fuel fill cap counterclockwise to remove it.

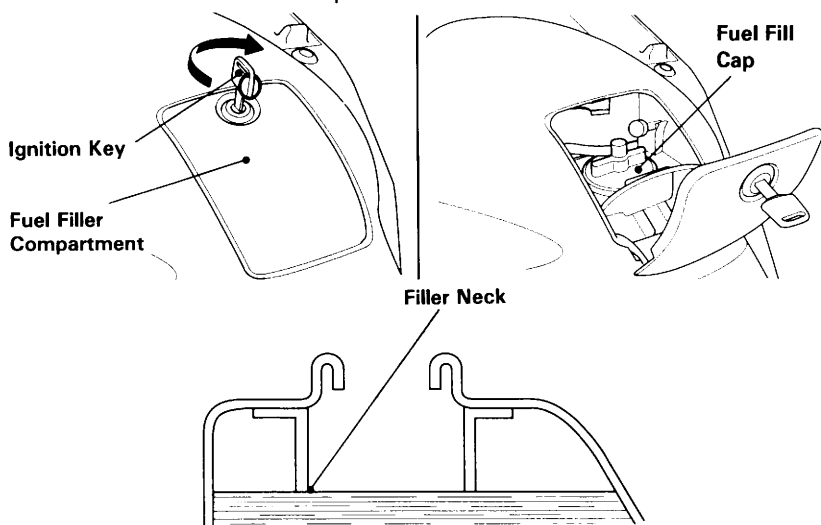

Use unleaded or low-lead petrol with a research octane number of 91 or higher. We recommend that you use unleaded petrol because it produces fewer engine and spark plug deposits and extends the life of exhaust system components.

FOR AUSTRALIA ONLY:

Use unleaded petrol with a research octane number of 91 or higher.

Never use stale or contaminated petrol or an oil/petrol mixture. Avoid getting dirt, dust or water in the fuel tank. Use of a lower octane petrol can cause persistent "pinging" or heavy "spark knock" (a metallic rapping noise) which, if severe, can lead to engine damage.

CAUTION:

- ***If “spark knock” or “pinging” occurs at a steady engine speed under normal load, change brands of petrol. If spark knock or pinging persists, consult your authorized Honda dealer. Failure to do so is considered misuse, and damage caused by misuse is not covered by Honda’s Limited Warranty.***

Occasionally you may experience light spark knock while operating under heavy loads. This is no cause for concern, it simply means your engine is operating efficiently.

Install the fuel fill cap by turning it clockwise. Be sure to properly route the hose attached to the top of the cap.

Close the fuel filler compartment lid with the key inserted and turned clockwise, then turn the key counterclockwise to lock the lid.

⚠ WARNING

- ***Petrol is extremely flammable and is explosive under certain conditions. Refuel in a well-ventilated area with the engine stopped. Do not smoke or allow flames or sparks in the area where petrol is stored or where the fuel tank is refueled.***
- ***Do not overfill the tank (there should be no fuel in the filler neck). After refueling, make sure the tank cap is closed properly and securely.***
- ***Be careful not to spill fuel when refueling. Spilled fuel or fuel vapor may ignite. If any fuel is spilled, make sure the area is dry before starting the engine.***
- ***Avoid repeated or prolonged contact with skin or breathing of vapor. KEEP OUT OF REACH OF CHILDREN.***

MAJOR COMPONENTS

(Information you need to operate this motorcycle)

Petrol Containing Alcohol

If you decide to use a petrol containing alcohol (gasohol), be sure its octane rating is at least as high as that recommended by Honda. There are two types of "gasohol": one containing ethanol, and the other containing methanol. Do not use gasohol that contains more than 10% ethanol. Do not use petrol containing methanol (methyl or wood alcohol) that does not also contain cosolvents and corrosion inhibitors for methanol. Never use petrol containing more than 5% methanol, even if it has cosolvents and corrosion inhibitors.

NOTE:

- Fuel system damage or engine performance problems resulting from the use of fuels that contain alcohol are not covered under the warranty. Honda cannot endorse the use of fuels containing methanol since evidence of their suitability is as yet incomplete.
- Before buying fuel from an unfamiliar station, try to find out if the fuel contains alcohol. If it does, confirm the type and percentage of alcohol used. If you notice any undesirable operating symptoms while using a petrol that contains alcohol, or one that you think contains alcohol, switch to a petrol that you know does not contain alcohol.

ENGINE OIL

Check engine oil level each day before operating the motorcycle.

To check the oil level:

1. Place the motorcycle on its center stand on firm, level ground.
2. Start the engine and let it idle for a few minutes.
3. Stop the engine. After a few minutes, check the oil level inspection window.

The oil level should be between the upper and lower level marks.

4. If required, remove the air duct/maintenance cover (page 71) and oil filler cap, add the specified oil up to the upper level mark. Do not overfill.
5. Reinstall the oil filler cap and the air duct/maintenance cover (if removed).

CAUTION:

- ***Running the engine with insufficient oil can cause serious engine damage.***

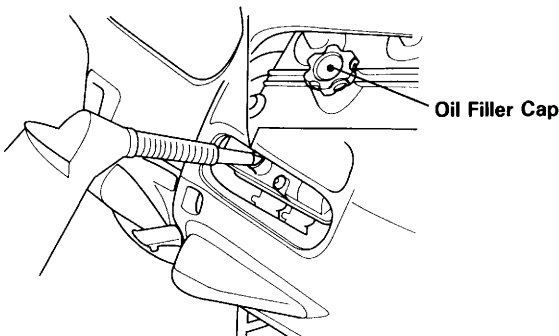
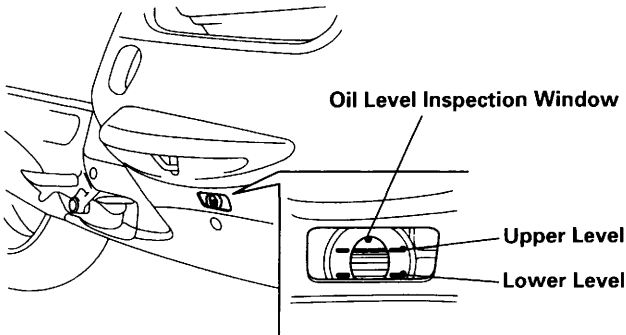

MAJOR COMPONENTS

(Information you need to operate this motorcycle)

Engine Oil

Good engine oil has many desirable qualities. Use only high detergent, quality motor oil certified on the container to meet or exceed requirements for API Service Classification SE, SF or SG.

Viscosity

Viscosity grade of engine oil should be based on average atmospheric temperature in your riding area. The following provides a guide to the selection of the proper grade or viscosity of oil to be used at various atmospheric temperatures.

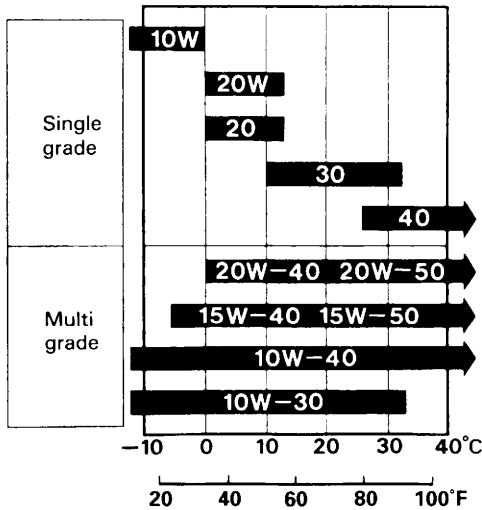

FINAL DRIVE OIL

Oil Level Check

Check the final drive oil level when specified by the maintenance schedule.

1. Place the motorcycle on its center stand on firm, level ground.
2. Remove the oil filler cap.
3. The oil level should be flush with the lower edge of the oil filler hole.

NOTE:

- If the level is low, check for leaks. Add the recommended oil through the oil filler hole until it reaches the lower edge of the opening.

Recommended Oil: HYPOID GEAR OIL SAE 80

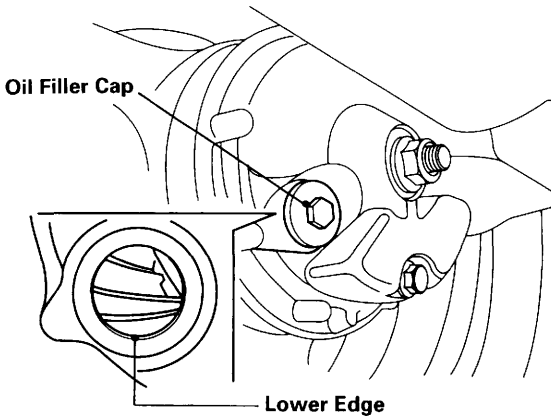

MAJOR COMPONENTS

(Information you need to operate this motorcycle)

TUBELESS TYRES

This motorcycle is equipped with tubeless tyres, valves, and wheel rims. Use only tyres marked "TUBELESS" and tubeless valves on rims marked "TUBELESS TYRE APPLICABLE."

Never mount tyres designed for use on automobiles on a motorcycle rim.

⚠ WARNING

- ***Any attempt to mount passenger car tyres on a motorcycle rim may cause the tyre bead to separate from the rim with enough explosive force to cause serious injury or death.***

Proper air pressure will provide maximum stability, riding comfort and tyre life. Check tyre pressure frequently and adjust if necessary.

NOTE:

- Tyre pressure should be checked before you ride while the tyres are "cold."
- Tubeless tyres have some degree of self-sealing ability if they are punctured, and leakage is often very slow. Inspect very closely for punctures, especially if the tyre is not fully inflated.

| | | Front | Rear |
|---|---|-----------------------------------|--|
| TYRE SIZE TYRE BRAND TUBELESS ONLY DUNLOP BRIDGESTONE | | 110/80 V18 D103F G547 | 160/70 V17 D103 G548 |
| TYRE SIZE TYRE BRAND TUBELESS ONLY METZELER | | 110/80 V18—V240 ME33 LASER | 160/70 VB17—V240 ME55A METRONIC |
| Cold tyre pressures psi (kPa, kgf/cm ²) | Up to 90 kg (200 lbs) load | 36 (250, 2.50) | 42 (290, 2.90) |
| | 90 kg (200 lbs) load to vehicle capacity load | 36 (250, 2.50) | 42 (290, 2.90) |

(Model equipped with CBS/ABS/TCS)

| | | Front | Rear |
|---|---|------------------------------------|-----------------------------------|
| TYRE SIZE TYRE BRAND TUBELESS ONLY DUNLOP BRIDGESTONE | | 120/70 ZR18 D202F BT-54F | 160/70 ZR17 D202 BT-54R |
| Cold tyre pressures psi (kPa, kgf/cm ²) | Up to 90 kg (200 lbs) load | 36 (250, 2.50) | 42 (290, 2.90) |
| | 90 kg (200 lbs) load to vehicle capacity load | 36 (250, 2.50) | 42 (290, 2.90) |